

This Page Is Inserted by IFW Operations
and is not a part of the Official Record

BEST AVAILABLE IMAGES

Defective images within this document are accurate representations of the original documents submitted by the applicant.

Defects in the images may include (but are not limited to):

- BLACK BORDERS
- TEXT CUT OFF AT TOP, BOTTOM OR SIDES
- FADED TEXT
- ILLEGIBLE TEXT
- SKEWED/SLANTED IMAGES
- COLORED PHOTOS
- BLACK OR VERY BLACK AND WHITE DARK PHOTOS
- GRAY SCALE DOCUMENTS

IMAGES ARE BEST AVAILABLE COPY.

**As rescanning documents *will not* correct images,
please do not report the images to the
Image Problem Mailbox.**



INTERNATIONAL APPLICATION PUBLISHED UNDER THE PATENT COOPERATION TREATY (PCT)

(51) International Patent Classification 6 : E21B 43/10, 19/22	A1	(11) International Publication Number: WO 98/07957 (43) International Publication Date: 26 February 1998 (26.02.98)
(21) International Application Number: PCT/IB97/00994 (22) International Filing Date: 15 August 1997 (15.08.97) (30) Priority Data: 08/698,662 16 August 1996 (16.08.96) US (71)(72) Applicant and Inventor: NOBILEAU, Philippe [FR/FR]; 40, chemin du Vinaigrier, F-06300 Nice (FR).	(81) Designated States: AU, BR, CA, CN, JP, MX, NO, RU, US, European patent (AT, BE, CH, DE, DK, ES, FI, FR, GB, GR, IE, IT, LU, MC, NL, PT, SE). Published With international search report.	
(54) Title: METHOD FOR CASING A WELLBORE		
(57) Abstract		
<p>Casing (15) is installed in a well in a folded collapsed condition by uncoiling it from a reel (87). Two strings of tubing (27, 29) extend continuously through the collapsed casing. One of the strings of tubing (27) is connected to a cement shoe (19) at its lower end of the casing. An opening tool (31) is located above the cement shoe (19) and includes a piston (33). The other string of tubing (29) extends to a pressure chamber (35) that is between the piston (33) and the cement shoe (19). After the casing (15) is lowered with a running tool to the desired depth, cement is pumped down the first string of tubing (27), which flows back up the annulus surrounding the casing. A liquid is then pumped down the second string of tubing (29) into the pressure chamber (35), causing the piston (33) to push the conical forming head upward (38, 39) relative to the casing (15) and the strings of tubing (27, 29). The forming head (38, 39) opens the casing (15) from the collapsed condition into a cylindrical configuration. The running tool (55) retrieves the strings of tubing and the opening tool (31) at the conclusion of the opening and drifting process.</p>		

FOR THE PURPOSES OF INFORMATION ONLY

Codes used to identify States party to the PCT on the front pages of pamphlets publishing international applications under the PCT.

AL	Albania	ES	Spain	LS	Lesotho	SI	Slovenia
AM	Armenia	FI	Finland	LT	Lithuania	SK	Slovakia
AT	Austria	FR	France	LU	Luxembourg	SN	Senegal
AU	Australia	GA	Gabon	LV	Latvia	SZ	Swaziland
AZ	Azerbaijan	GB	United Kingdom	MC	Monaco	TD	Chad
BA	Bosnia and Herzegovina	GE	Georgia	MD	Republic of Moldova	TG	Togo
BB	Barbados	GH	Ghana	MG	Madagascar	TJ	Tajikistan
BE	Belgium	GN	Guinea	MK	The former Yugoslav Republic of Macedonia	TM	Turkmenistan
BF	Burkina Faso	GR	Greece			TR	Turkey
BG	Bulgaria	HU	Hungary	ML	Mali	TT	Trinidad and Tobago
BJ	Burkina Faso	IE	Ireland	MN	Mongolia	UA	Ukraine
BR	Brazil	IL	Israel	MR	Mauritania	UG	Uganda
BY	Belarus	IS	Iceland	MW	Malawi	US	United States of America
CA	Canada	IT	Italy	MX	Mexico	UZ	Uzbekistan
CF	Central African Republic	JP	Japan	NE	Niger	VN	Viet Nam
CG	Congo	KE	Kenya	NL	Netherlands	YU	Yugoslavia
CH	Switzerland	KG	Kyrgyzstan	NO	Norway	ZW	Zimbabwe
CI	Cote d'Ivoire	KP	Democratic People's Republic of Korea	NZ	New Zealand		
CM	Cameroun	KR	Republic of Korea	PL	Poland		
CN	China	KZ	Kazakhstan	PT	Portugal		
CU	Cuba	LC	Saint Lucia	RO	Romania		
CZ	Czech Republic	LJ	Liechtenstein	RU	Russian Federation		
DE	Germany	LK	Sri Lanka	SD	Sudan		
DK	Denmark	LR	Liberia	SE	Sweden		
EE	Estonia			SG	Singapore		

METHOD FOR CASING A WELLBORE

Technical Field

This invention relates in general to installing well casing in oil and gas wells and in particular to a method involving fabricating and collapsing casing, running the collapsed casing into the well and opening the casing into a cylindrical configuration.

Background Art

Oil and gas wells are typically drilled by installing a conductor pipe to first depth, then drilling the well to a second depth. A string of casing is made up by coupling together sections of pipe, each being about forty feet long and lowering it inside the conductor pipe in a nested arrangement. Cement is then pumped down the casing which flows back up the annulus between the casing and the open borehole. Drilling is resumed to a third depth and the process is repeated with another smaller diameter nested casing. An even smaller diameter string of casing may be installed at a fourth depth.

These casings serve to support the borehole wall and to prevent undesired outflow of drilling fluid into the formation or inflow of fluid from the formation into the borehole from strata other than the target production strata. The nested arrangement requires a relative large borehole at the upper part of the wellbore due to the thickness of casing couplings and also due to the minimum clearance necessary between casing to displace cement in the annulus space.

Larger borehole are more costly to drill since they require larger drill bits, more mud, and more cuttings disposal. Also, a larger diameter pipe has a lower pressure rating for the same wall thickness than a smaller diameter pipe, in consequence the casing have to cover the previous one up to the wellhead to enhance the pressure capability as the well goes deeper. Also conventional casing requires a derrick to make-up the pipe sections and lower the casing string into the well. Derricks are big and costly to move, and running casing in forty foot section is time consuming.

Liners are employed in some wells. A liner is similar to a casing, however, rather than extending completely to the surface wellhead, the upper end of the liner is suspended on the lower end of the previous string. Liners still must be run by making-up pipe sections together and are employed usually to extend in limited lengths from only the smallest diameter full length casing installed.

Coil tubing units permit one to rapidly run a continuous metallic tubing into a well. The tubing is plastically coiled on large reels. A pushing mechanism straightens up the tubing and lowers it into the well as it is uncoiled from the reel. Coil tubing is used to circulate fluids into wells for various purposes. However, it is seldom used to serve as casing due to its small diameter. Coil tubing is smaller in diameter than typical casing, which have usually a minimum diameter of five inches. It would require a large reel to be able to coil several thousand feet of metallic casing of five inches in diameter or larger.

Disclosure of Invention

In this invention, a metal strip plate is formed in a generally tubular configuration, and welded longitudinally with at least one string of continuous tubing

CONFIRMATION COPY

inserted during the manufacturing process. Alternatively circular pipe sections about forty feet long are welded together and strings of tubing are threaded inside. The casing is then collapsed with the tubing located therein and wound on a small reel due to its small height by comparison to its nominal diameter. The upper and lower end portions of the casings are generally formed in a somewhat cylindrical configuration. An opening tool is located in the lower end cylindrical portion. The opening tool has a piston and a conical forming head located above the piston. A pressure chamber is created below the piston in the lower end portion of the casing.

The casing is deployed from the reel and folded in a horseshoe shape prior to entering the well. When the casing has reached the proper depth, a fluid is pumped down the tubing into the pressure chamber to open the casing into a cylindrical shape. The fluid pressure acts against the piston to push the opening tool upward. This causes the head of the opening tool to form the casing from the collapsed/folded configuration into a cylindrical configuration. The forming tool and the tubing are then pulled from the casing.

Preferably, two strings of tubing are installed in the casing while it is being manufactured. One of the strings of tubing serves to pump a cement slurry down through a cement shoe located at the lower end of the casing. The cement flows back up the annulus surrounding the casing to cement the casing in place. Then fluid is pumped down the other string of tubing to open the casing.

Also after the opening tool reaches the upper end of the casing, a forging tool is used to expand the upper end cylindrical portion of the casing into a metal to metal sealing engagement with the lower end of the previously cased section of the well. In the preferred embodiment, this involves releasing the running tool from the upper end of the casing after the collapsed portion of the casing has been expanded, then lowering the forging tool located above the running tool into the casing. Fluid is then pumped down to radially forge the upper end of the casing into engagement with the lower end of the previous one.

The opening tool includes a forming head with a conical body with flutes. Balls roll along the flutes in rolling engagement with the casing wall as it is being opened to a cylindrical configuration. The balls force the opening of the casing as they roll along the flutes. The balls roll from the flutes into a lower ball passage, an axial passage, into an upper passage, and back into the flutes in a continuous cycle. Alternatively, the forming head comprises a conical body with thin dual conical segments to increase the forming head diameter

Brief Description of Drawings

Figures 1A-1D comprise a vertical sectional view of an assembly for casing a well, including a collapsed string of casing being installed in a well along with a running tool and an opening tool.

Figure 2 is a cross sectional view of a portion of the running tool of the assembly of Figures 1A-1D, taken along the line 2-2 of Figure 1B.

Figure 3A is a sectional view of another portion of the running tool of the assembly of Figures 1A-1D, taken along the line 3-3 of Figure 1B.

Figure 3B is another sectional view of the running tool taken along the line 3-3 of Figure 1B, but showing the running tool shifted to a released position.

Figure 4 is a sectional view of an intermediate portion of the casing of the assembly of Figure 1, taken along the line 4-4 of Figure 1B.

Figure 5 is a sectional view of a portion of the opening tool of the assembly of Figure 1C, taken along the line of 5-5 of Figure 1C.

5 Figure 6 is another sectional view of a portion of the opening tool of Figure 1C, taken along the line 6-6 of Figure 1C.

Figure 7 is a sectional view of the cement shoe of Figure 1D, taken along the line 7-7 of Figure 1D.

10 Figures 8A and 8B comprise a sectional view of a portion of the assembly of Figure 1, shown after cementing and during the opening of the intermediate portion of the casing.

Figure 9 is a sectional view of the assembly of Figure 8A, taken along the line 9-9 of Figure 8A.

15 Figure 10 is a sectional view of the assembly of Figure 8A, taken along the line 10-10 of Figure 8A.

Figure 11 is a sectional view of the assembly of Figure 8B, taken along the line 11-11 of Figure 8B.

20 Figure 12 is a sectional view of the forging packers of the assembly of Figure 1A, shown lowered into the upper end portion of the casing and in the process of forging the upper end portion of the casing into sealing and locking engagement with the lower end of the upper cased section.

Figure 13 is a sectional view of one of the forging packers of Figure 12, taken along the line 13-13 of Figure 12.

25 Figure 14 is a sectional view of the well of Figures 1A-1D, shown after the casing has been set and the installation apparatus retrieved.

Figure 15 is a schematic sectional view illustrating a step in manufacturing the collapsible casing of Figures 1A-1D.

Figure 16 is another schematic sectional view of the casing of Figure 1A-1D, showing the addition of an outer layer in the case of a multiple layer casing

30 Figure 17 is another schematic sectional view of the casing of Figure 16, showing the welding of the additional layer.

Figure 18 is a sectional view illustrating one of the end portions of the casing of Figures 1A-1D with a dual layer configuration.

35 Figure 19 is a schematic view illustrating the collapsed casing of Figures 1A-1D being uncoiled from a reel, folded in a horse shoe shape and lowered into a well.

Figure 20 is a flattened sectional view of the casing of Figure 19, shown along the line 20-20 of Figure 19.

Figure 21 is a folded sectional view of the casing of Figure 19, shown along the line 21-21 of Figure 19.

40 Figure 22 is a schematic view illustrating valves for controlling the flow of fluids to the installation apparatus of Figures 1A-1D.

Figure 23 and 24 are isometric views illustrating an alternative design for the opening tool including expander segments.

45 **Best Mode for Carrying Out the Invention**

Referring to Figures 1A-1D, the well illustrated has a cased section 11 which

has already been cemented in place and an open hole section 13 which extends below cased section 11 to the target depth. A continuous string of casing 15 according to the invention is shown in place in the well with a lower end portion 15a at the lower end of the well open hole section 13. Casing 15 has an intermediate portion 15b that extends from the lower end portion upward, typically several thousand feet, to an upper end portion 15c. Upper end portion 15c overlaps the lower portion of cased section 11. Casing lower and upper end portions 15a, 15c each are somewhat cylindrical with axially extending corrugations 17 as shown in Figure 5. Corrugations 17 are straight axially extending channels on both the inner and outer diameters of casing, providing inward protruding valleys 17a alternating with outward protruding peaks 17b. Intermediate portion 15b, shown in Figure 4, is collapsed and folded, having a bight 18 that curves inward and touches the opposite side, which is generally arcuate when lowered into the wellbore.

Referring to Figure 1D, a cement shoe 19 is located at the lower end of casing lower end portion 15a. Cement shoe 19 provides an end cap for casing 15 and is made of drillable material with a cementing port 20 extending axially through it. A metal stinger 21 engages sealingly into the upper portion of cementing port 20. Stinger 21 is a tubular member having a conduit 23 for pumping down a cement slurry through cementing port 20 which flow back up the annulus space surrounding the casing 15, as indicated by the arrows. Stinger 21 has also some flow ports 25 which are isolated from conduit 23 and lead to the exterior of stinger 21.

A cement slurry tubing 27 extends continuously through casing 15, and has its lower end coupled to stinger 21 for connecting with conduit 23. Similarly, a fill-up tubing 29 extends continuously through casing 15 and has its lower end coupled to stinger 21 for delivering fluid to ports 25. Tubing strings 27, 29 are, conventional metal coiled tubing strings of about one inch in diameter.

An opening tool 31 is housed in casing lower end portion 15a, shown in Figure 1C, above stinger 21. Opening tool 31 includes on its lower end a piston 33. Piston 33 is an elastomeric cup sliding seal, which has straight axially extending grooves on its exterior for meshing with the corrugations 17 of casing lower end portion 15a. Piston 33 has a packing element 33a to seal around tubing strings 27, 29. A pressure chamber 35 is located in the space surrounding stinger 21 above cement shoe 19 and below piston 33. In the running-in position, as shown in Figure 1D, pressure chamber 35 is at its minimum volume. A cylindrical metal piston head 37 extends upward from piston 33. Piston head 37 is engaging a sleeve 48 which has a smaller outer diameter than the inner diameter of casing lower end portion 15a at valleys 17a.

Opening tool 31 has a tapered or conical forming head 39 that tapers from a smaller diameter upper end to a larger diameter at lower end. Head 39 has vertical flutes 41 which align with valleys 17a, as shown in Figure 5. A plurality of balls 43 roll down flutes 41 of head 39. Balls 43 are movable through two axial passages 45, a plurality of lower lateral passages 47, and a plurality of upper lateral passages 49. Piston head 37 initially is in a lower position within a sleeve 48 of head 39, providing a chamber for a number of balls 43 as shown in Figure 1C. When piston head 37 is pushed upward, until it will enter in contact with a flange 50 of head 39 as shown in Figure 8A, it will push the balls 43 upward through axial passages 45. Balls 43 move outward on upper ball passages 49, down flutes 41, and back inward in lower ball

passages 47 to axial passages 45 in a continuous cycle as body 39 moves upward in casing 15.

Referring again to Figure 1C, opening tool 31 has a cylindrical top end 51 which has an outer diameter equal to the minimum inner diameter of casing lower end portion 15a, which is measured at valleys 17a. Balls 43 will engage valleys 17a when contained in flutes 41 and bend the casing wall to line up with expanded peaks 17b. While at the upper end of flutes 41, the diameter from one ball 43 to an opposite ball 43 is substantially equal to the diameter between valleys 17a. When balls 43 are at the lower ends of flutes 41, as shown in Figure 8A, the outer diameter of forming tool 31 measured from one ball 43 to an opposite ball 43 at the lower ends of flute 41 is greater than the minimum inner diameter of casing lower end portion 15c. Consequently, balls 43 push valleys 17a outward to open, in a smooth circular configuration, the upper end of casing lower portion 15a as opening tool 31 moves upward.

Due to the relative stiffness of the casing metal wall, the intermediate portion 15b is opened from its folded configuration ahead of the opening tool 31, and the contact between the inner wall and the opening tool 31 is made only by the balls 43 rolling on flutes 41 of the conical forming head 39.

Referring to Figure 1B, a running tool 55 is located at the top of casing upper end portion 15c. Running tool 55 is a tubular member which has an outer sleeve 56. The exterior of outer sleeve 56 has vertical grooves 58 between vertical bands 58a. Outer sleeve has a set of threads on bands 58a which engages a mating set of threads 57 formed on valleys 17a in the upper inside end of casing upper end portion 15c. Because of corrugations 17 and grooves 58, threads 57 will be discontinuous and located only on the valleys 17a.

Outer sleeve 56 is supported by an inner body 59, which has a smooth cylindrical exterior. Outer sleeve 56 has a J-pin 61 that protrudes inwardly into an elongated U-shaped J-slot 63 formed in outer body 59. J-slot 63 has a first leg 63a and a parallel second leg 63b joined at the bottom. During running-in of casing 15, J-pin 61 will be at the upper end of the first leg 63a and maintained in this position by the weight of the casing 15 hanging on the running string connected to the inner body 59. After casing intermediate portion 15b has been opened, the weight of the casing 15 is supported by the numerous contacts with the inner wall of the borehole. After opening has been completed, the operator will lower the running string 72, which lowers the inner body 59 relative to outer sleeve 56. Subsequently, the operator will pick up the running string 72 to place the J-pin 61 in the second leg 63b. This causes sleeve 56 to rotate an increment, as shown by the arrow in Figure 3B, disengaging the threads on outer sleeve 56 from threads 57. Bands 58a on outer sleeve 56 align with peaks 17b, allowing running tool 55 to be lowered into casing upper end portion 15c.

Running tool 55 has a main supply passage 64 connected to the passage in the lower part of packer string 69 which extends into inner body 59. A cement slurry passage 65 (Fig. 3A) connected to tubing string 27 is located in running tool 55 and can be connected to the lower end of main supply passage 64. Similarly, a fill-up passage 67 connected to tubing string 29 can be connected to the lower end of main supply passage 64.

Inner body 59 of running tool 55 is connected to the packer string 69 by

threads. The upper part of packer string 69 features a centralizer 70. Two or more forging packers 71 are mounted on the packer string 69 between centralizer 70 and inner body 59. Forging packers 71, when supplied with high internal pressure from a down hole pressure multiplier (not shown), will inflate and radially expand to plastically forge the upper end of casing upper end portion 15c, as shown in Figure 12. Hydraulic passages 73, extending through packer string 69, can be connected via pressure multiplier to lower end of main supply passage 64 within running tool inner body 59. Packer string 69 is connected at centralizer 70 to a the running string 72 which extends to the surface. Preferably, running string 72 is another string of coiled tubing approximately two inches in diameter. Packers 71 have external axial grooves 74 which will align with valleys 17a of casing upper end portion 15c when packers 71 are lowered into upper end portion 15c with the centralizer 70 landed on top of the casing 15c as shown in Figure 12.

Referring to Figure 22, in the preferred embodiment, electrically actuated valves 75, 77 and 79 are mounted in running tool inner body 59 (Fig. 1B). Valve 75 is in slurry passage 65 and opens and closes flow to tubing 27. Valve 77 is in opening fluid passage 67 for opening and closing flow from main supply passage 64 to tubing 29. Valve 79 is in pressure passage 73 for opening and closing pressure fluid from main supply passage 64 to forging packers 71 (Fig. 1A). Electrical valve control wires (not shown) extend through coiled running string 72 to the surface to a control panel. A small accumulator (not shown) supplies hydraulic fluid to valves 73, 77, 79 to open and close them when electrically actuated. Pumps 80 on the surface, which could be either cement or mud pumps are used for delivering pressure fluid down main supply passage 64.

Referring now to Figure 15, casing 15 is fabricated by drawing a first metal strip 81 from a reel and bending two edges down around two laterally spaced apart, parallel continuous strings of coil tubing 27, 29. As shown in Figure 16, the edges are bent over and welded at seam 82. The upper side is bent into a concave shape touching seam 82, while the lower side is flat. Then, a second strip 83 is drawn from a reel and bent to have upturned edges. As shown in Figure 17, second strip 83 is then bent by rollers around first strip 81 while first strip 81 is in the configuration shown in Figure 16. Rollers then bend the upper side of strip 83 into a concave shape as shown in Figure 20. Casing 15 thus is double-walled and has a flat side 85 that extends between parallel tubing strings 27, 29, generally tangent to outer diameter portions of tubing strings 27, 29.

The use of two walls for casing 15 reduces the amount of strain that would otherwise occur during opening plastic deformation with a single wall casing having the same total thickness. Three or more wall casings might be desirable in certain cases. Casing made of multiple wall needs good friction between the wall to resist external pressure. Known friction enhancing techniques such as surface stamping, surface treatment or coating are desirable to offer adequate external pressure capability when open. Also the circumference of the external wall can be made slightly smaller than the previous one to offer adequate fretting of the wall when casing is open.

Casing 15 will be coiled on a reel 87 (Fig. 19) while in the configuration shown in Figure 20. Reel 87 is a large member capable of holding up to 5000 feet of casing

15 which has a 5-1/2 inch external diameter when expanded to a cylindrical configuration. Figure 18 illustrates corrugations 17 which are formed on both the upper and lower end portions 15c, 15a (Figs 1B, 1D) by a roller corrugating operation. The upper and lower end portions 15c, 15a remain generally cylindrical, although corrugated. The straight upper and lower end portions 15c, 15a are only a few feet in length and are not wound on reel 87 during transportation from the manufacturing plant to the well site.

When deploying casing 15 from reel 87, casing intermediate portion 15b will first pass through a set of bending rollers 89 as shown schematically in Figure 19. Folding rollers 89 will form casing 15 from the collapsed flattened configuration of Figure 20 to the folded collapsed configuration shown in Figure 21. This creates bight 18, and positions tubing strings 27, 29 closer toward each other. The maximum width of casing intermediate portion 15b in the rounded collapsed configuration of Figure 21, is less than the inner diameter of cased section 11 (Fig. 1A). The maximum width of casing intermediate portion 15b while in the collapsed flattened configuration of Figure 20 is greater than the inner diameter of cased section 11. Associated with the folding rollers 89, a gripping and pushing mechanism 91 is employed. The folding pushing mechanism 91 is constructed generally as in a conventional coil tubing pushing mechanisms. It grips casing 15 without deformation, pulls it from reel 87, and pushes it downward into the well. The horseshoe shape of Figure 21, resists the compression applied by gripping and pushing mechanism 91 while being pushed into the well.

During installation, casing 15 will be uncoiled from reel 87 and pushed by mechanism 91 into the well until cement shoe 19 is close to the bottom of open hole section 13. The length of casing 15 will be previously selected so that the upper end of portion 15c extends into cased section 11 (Fig. 1B), overlapping it over a substantial length. Valves 77, 79 are closed and valve 75 (Fig. 22) is open and cement pump 80 pumps a cement slurry 92 (Fig. 9) down the passage 64, 65 through open valve 75 and down cement slurry tubing 27. As shown by the arrows in Figure 1D, the cement slurry flows down passages 23, 20 and flows up the annulus space surrounding casing 15.

A selected volume of cement will be pumped based on an estimate of the total volume of the annulus as if casing 15 had already been opened to the cylindrical configuration. Because of the collapsed rounded or horseshoe configuration of casing intermediate portion 15b, a much greater annulus volume initially will be present around casing intermediate portion 15b, as shown in Figure 9, facilitating circulation. Consequently, initially, cement 92 will normally not completely fill the annulus to the top of casing upper portion 15c. During the pumping of cement, displaced drilling fluid, or returns, will flow up the corrugations 17 of the casing upper end section 15c into the annulus surrounding running tool 55 flow by ports 60. The returns flow up around the forging packers 71 and around the annulus surrounding running string 72 to the surface.

After pumping the calculated volume of cement slurry, a selected volume of flushing fluid will be pumped down cement slurry tubing 27. The volume is selected to be just the amount needed to push cement slurry from conduit 72, tubing 27 and stinger 21 into the open borehole, but substantially no more. The valve 75 is then closed and valve 77 is open. Drilling fluid is pumped down conduit 72, which flows

through passages 64, 67 and down fill-up tubing 29. The fluid flows out ports 25 into pressure chamber 35, shown in Figure 1D.

As shown in Figure 8B, the fluid pushes upward on piston 33, which slides upward relative to tubing strings 27, 29. Piston head 37 pushes balls 43 from the space in sleeve 48 upward into passages 45, as can be seen by comparing Figure 1D with Figure 8A. Once in contact with flange 50, the force exerted by piston head 37 begins to push the opening tool 31 upward while tubing strings 27, 29 remain stationary. Due to the engagement of balls 43 with head 39 and casing lower end portion 15a, balls 43 are forced to roll down the inclined flutes 41, pushing the valleys 17a outward to first remove corrugations 17 of the casing lower end 15a and open the intermediate portion 15b.

After a short distance, all of the balls 43 will be in engagement with conical body 39, as shown in Figure 8A. Upper end 51 will move upward into the intermediate portion 15b. Balls 43 will open casing from the collapsed folded configuration of Figure 9 to the cylindrical configuration of Figure 10. During the casing expansion process, the annulus surrounding casing intermediate portion 15b decreases, pushing cement slurry 92 upward, and returns will flow up into the channel spaces between corrugations 17 of casing upper end portion 15c and cased section 11. Some of the cement slurry 92 will flow out above running tool 55 to insure a proper seal between casings when they will be later forged together. As forming tool 31 moves upward, the volume of pressure chamber 35 increases. This process will continue for the entire length of the casing which could exceed several thousand feet.

Eventually, forming tool 31 will reach casing upper end portion 15c. At this point, balls 43 will push outward on valleys 17a to round the corrugated configuration 17 into a cylindrical configuration in the same manner as at casing lower end portion 15a. Forming tool 31 will eventually contact the lower end of running tool 55, which protrudes a short distance into casing upper end portion 15c, shown in Figure 1B.

The running tool 55 will be released from threads 57 by letting running string 72 go down a short distance, then pulling upward. While lowering, tubing strings 27, 29 will spiral slightly along their lengths to accommodate the compression. The downward movement of inner body 59 relative to outer sleeve 56 causes J-pin 61 to move from first leg 63a to second leg 63b. When this occurs, an incremental amount of rotation of sleeve 56 occurs relative to inner body 59. This rotation, as illustrated in Figure 3B, causes threads 57 to disengage from the threads on sleeve 56, releasing running tool 55 from casing upper end portion 15c. Grooves 58 on outer sleeve 56 will now be aligned with valleys 17a.

The operator then again drop running string 72 to place forging packers 71 within casing upper end portion 15c as shown in Figure 12. Because of the alignment of axial external grooves 58 and external grooves 74 (Figs. 1A, 1B) with corrugations 17, outer sleeve 56 and packers 71 will pass downward within casing upper end portion 15c. Centralizer 70 is closely spaced to the inner diameter of cased section 11, and will land on the upper edge of casing upper end portion 15c. Valve 77 is now closed and valve 79 open (Fig. 22). Pressurized fluid is supplied with mud pump 80 through running string 72. This pressure which will be multiplied by a known pressure multiplier, causes the forging packers 71 to inflate and plastically deform a portion of upper end portion 15c out into a tight gripping and sealing engagement with cased

section 11.

The fluid pressure is then bled off to allow forging packers 71 to retract. The running string 72 is lifted to pull up running tool 55. Tubing strings 27, 29 will move upward along with stinger 21 and opening tool 31. The entire assembly is pulled out of the well and reel back on the reel 87. Figure 14 illustrates casing 15 without the installation apparatus. Casing hydrostatic pressure tests can then be done against the shoe and drilling can resume just after. Also, Figure 14 shows that cased section 11 may be of a continuous expandable type installed as a liner to another cased section 93. Cased section 93 is shown to again be an expandable type installed in the same manner as described and located within a conductor 95 that is threaded to a wellhead 97.

Figures 23 and 24 illustrate an alternative design for the opening tool 31 where in lieu of balls on inclined flutes which circulate in a cycle, expander dual conical segments 34 and 36 slide downward from an upper retracted position (Fig. 23) to a lower expanded position (Fig. 24), then stop against a shoulder 38a located at the bottom of the conical forming head 38. The segments 34 comprises a main segment 34a sliding along a retaining guide 38b attached on the conical forming head 38. On both sides of segment 34a, two segments 34b are hinged. Segments 36 which complete the expanding ring 30 (Fig. 24) slide on its own retaining guide 38c also attached on the conical forming head 38. A stabilizer 38d is attached on the top of the conical forming head 38 to prevent contact between the segments and the ID of the corrugated portion for easier installation of the opening tool. The fingers of the stabilizer 38d bend when the tool is pumped up allowing the segments to contact the casing internal surface. The dual conical segments 34a, 34b and 36 can be made of ductile ceramic or coated with ductile ceramic to prevent galling when operating the opening tool.

The piston 33 (Fig. 23) is an elastomeric cup sliding seal with straight axially extending groove to fit the corrugated end straight section of the casing which comprise two parts: a metal support washer 33b which is corrugated and bonded to an elastomeric packing element 33c and a lip type seal 33d. Figure 24 illustrates the deformation of the piston 33 with the support washer 33b being flattened up and elastomeric parts 33c and 33d deformed to cylindrical external surfaces by the fluid pressure.

The invention has significant advantages. As can be seen in Figure 14, the difference in the inner diameters of one cased section to the next upward cased section is no greater than the wall thickness of the lower cased section. This reduces substantially the loss diameter from one casing string to another, allowing almost monodiameter drilling. It allows a smaller cased section at the top of the well for a given bottom diameter and depth than prior art wells. Monodiameter drilling allows smaller bits, less mud, less cuttings to be disposed of, and less cement to achieve the same final size well. This method allows one to have shorter and more different diameter strings than in the prior art. The method can be performed without the need for a hoisting mast if drilling is done by turbine driven drill bit on coiled tubing.

While the invention has been shown in only one of its forms, it should be apparent to those skilled in the art that it is not so limited, but is susceptible to various changes without departing from the scope of the invention. For example, rather than

coiled tubing running string 72, if a hoisting mast is available, conventional drill pipe may be used. In that event, rather than electrically actuated valves, the valving can be accomplished by balls or darts down the conduit 64 to selectively close and open the passages. Also, rather than elastomeric packers for expanding the casing upper end
5 portion, other pressure actuated metal radially expandable members may be employed

Claims

1. An apparatus for casing a well, the improvement characterized by the combination of:
a continuous metal casing (15) that is wound onto a reel (87) into a generally collapsed configuration (Fig. 20);
5 deploying means (Fig. 19) for deploying the casing from the reel into the well;
and
 opening means to open in-situ the continuous metal casing from the collapsed configuration into a cylindrical configuration.
- 10 2. The apparatus according to claim 1, wherein the opening means consists of an opening tool (31), comprising a piston (33), a conical forming head (38, 39), above the piston (33) and forming a pressure chamber (35) between a closed end and the piston, located in a closed straight end portion of the casing that is generally cylindrical and means for pumping a fluid into the pressure chamber, which acts against the piston
15 (33) to push the opening tool inside the continuous metal casing (15) causing the conical forming head (38, 39) to radially open the continuous metal casing (15) from the collapsed configuration into a cylindrical configuration.
- 20 3. The apparatus according to claim 2, wherein the closed straight end portion of the casing (15) has axially extending corrugations (17) having a maximum radial dimension not exceeding the radial dimension of the casing (15) in the cylindrical configuration.
- 25 4. The apparatus according to claim 2, wherein there is, at least, one string of tubing (29) located inside the casing and the opening tool piston has sealing means (33a) around the tubing.
- 30 5. The apparatus according to claim 4, wherein the opening tool (31) is located in a closed lower end portion of the casing (75a) with the pressure chamber (35) below it and the fluid is pumped down the string of tubing (29) into the pressure chamber (35) acting against the piston (33) to push the opening tool (31) upward.
- 35 6. The apparatus according to claim 4, wherein there are means for pumping a cement slurry down the tubing (27), which flows back up an annulus surrounding the casing.
- 40 7. The apparatus according to claim 2, wherein there are means on the opening tool (31) for engaging the collapsed portion of the casing in rolling contact (43) as the opening tool bends the casing wall into the generally cylindrical configuration.
- 45 8. The apparatus according to claim 2, wherein there are means on the opening tool (31) for increasing the diameter of the conical forming head (38, 39).
9. The apparatus according to claim 8, wherein the means to increase the diameter of the conical forming head (38) are expander dual cone conical segments (34a, 34b, 36) located in a retracted position and are staggered further up and in contact with the

conical forming head (38).

10. The apparatus according to claim 9, wherein external surfaces of the conical segments (34a, 34b, 36) are ceramic.
11. The apparatus according to claim 1, wherein while the casing (15) is on the reel (87), the casing has a generally flattened configuration (Fig. 20) and wherein the deploying means (Fig. 19) also comprises bending means for bending the flattened configuration of the casing into an arcuate generally horseshoe configuration (Fig. 21) as the casing (15) is deployed from the reel (87) and prior to entry into the well.
12. The apparatus according to claim 11, wherein there are two strings of tubing (27, 29) located inside the casing at both ends of the flattened configuration (Fig. 20).
13. The apparatus according to claim 1, wherein there are:
a straight upper end portion of the casing (15c) that is generally cylindrical;
a running tool (55);
releasable means (57) for attaching the running tool to the upper end portion of the casing;
means for attaching the running tool to a running string (72) for lowering the casing in the well;
the releasable means releasing the running tool (55) from the upper end of the casing after the casing has been opened into the cylindrical configuration for retrieving the running string (72) and running tool (55).
14. The apparatus according to claim 13, wherein there are:
at least, one string of tubing (29) located inside the casing and the opening tool piston has sealing means (33a) around the tubing.
means for securing the upper end of the string of tubing (27, 29) to the running tool;
means to retain the opening tool on the string of tubing;
the releasable means releasing the running tool (55) from the upper end of the casing for retrieving the running string (72), the opening tool (31) and the string of tubing (27, 29) after the casing has been opened into cylindrical configuration.
15. The apparatus according to claim 1, wherein the well has an upper cased section (11), and wherein the apparatus further comprises means (71, 74) for plastically deforming the upper end of the casing (15c) into engagement with the upper cased section of the well (11).
16. The apparatus according to claim 1, wherein the casing comprises at least two concentric sleeves (81, 83) in tight contact with each other.
17. The apparatus according to claim 3, wherein the corrugated casing straight end portion (15a, 15c) comprises at least two concentric sleeves (81, 83) in tight contact with each other.

18. The apparatus according to claim 1, wherein there are:
first and second strings of tubing (27, 29);
a continuous metal casing (15) having an intermediate portion (15b) formed in
5 a generally flattened configuration (Fig. 20) with the first and second strings of tubing
contained therein and laterally spaced apart;
the casing having a generally cylindrical lower end portion (15a);
an opening tool (31) located in the lower end portion which has a piston (33)
and a conical forming head (38, 39);
10 a cement shoe (19) at the lower end portion below the piston (33) which can
be made in communication with at least one string of tubing (27);
a pressure chamber (35) in the lower end portion of the casing below the
piston (33) and above the cement shoe (19), and which can be made in communication
at least one string of tubing (29);
15 a running tool (55) attached to the upper end portion of the casing, the first
(27) and second (29) strings of tubing having upper ends which terminate at the
running tool (55); the running tool (55) being secured to a running string (72) for
lowering the running tool (55) and the upper end portion of the casing (15c) in the
cased section of the well (11) and the intermediate portion (15b) and the lower end
20 portion of the casing (15a) in the open hole section of the well (13);
cement pumping means for pumping cement down at least one string of tubing
(27) and out the cement shoe to return up the annulus surrounding the casing;
fluid pumping means for pumping a fluid down at least one string of tubing
(29) into the pressure chamber, which acts against the piston (33) to push the opening
25 tool (31) upward relative to the casing (15) and the string of tubing, causing the
forming head (38, 39) of the tool to bend the casing wall of the intermediate portion
into a cylindrical configuration; and
means for releasing the running tool (55) from the upper end portion of the
casing (15c) and retrieving the running tool (55), the opening tool (31) and the first
30 (27) and second (29) strings of tubing after the intermediate portion of the casing
(15b) has been opened into the cylindrical configuration.
19. A method for casing in a wellbore, comprising:
35 collapsing a continuous metal tubular casing (15) and winding the casing onto
a reel (87);
lowering the casing from the reel into the well (Fig. 19); and
opening the casing (15) from the collapsed configuration into a cylindrical
configuration.
- 40 20. A method according to claim 19, further comprising:
placing at least one string of tubing (27) into the metal tubular casing prior of
collapsing and winding the metal tubular casing onto a reel (87);
placing in a closed end portion of the casing an opening tool (31) which has a
piston (33) and a conical forming head (38, 39) and providing a pressure chamber (35)
45 between the closed end portion and the piston (33);
lowering the casing (15) from the reel (87) into the well; and pumping a fluid

into the pressure chamber (35), which acts against the piston (33) to push the opening tool (31) relative to the casing (15), causing the forming head to radially open the casing from the collapsed configuration into a cylindrical configuration.

- 5 21. A method according to claim 20, further comprising:
- placing two strings of tubing (27, 29) into the metal tubular casing prior to flattening the tubing and winding the metal tubular casing onto a reel (87);
 - 10 placing in a closed bottom end corrugated straight portion of the casing (15a) the opening tool (31) which has retractable opening/drift means;
 - lowering the casing (15) from the reel (87) into the well and bending the flattened configuration of the casing; and
 - 15 pumping a fluid down the tubing into the pressure chamber (35), which acts against the piston (33) to push the opening tool (31) relative to the casing (15), causing the forming head (38, 39) to grow to its nominal drifting dimension to open and drift the casing from the collapsed configuration into a cylindrical configuration.

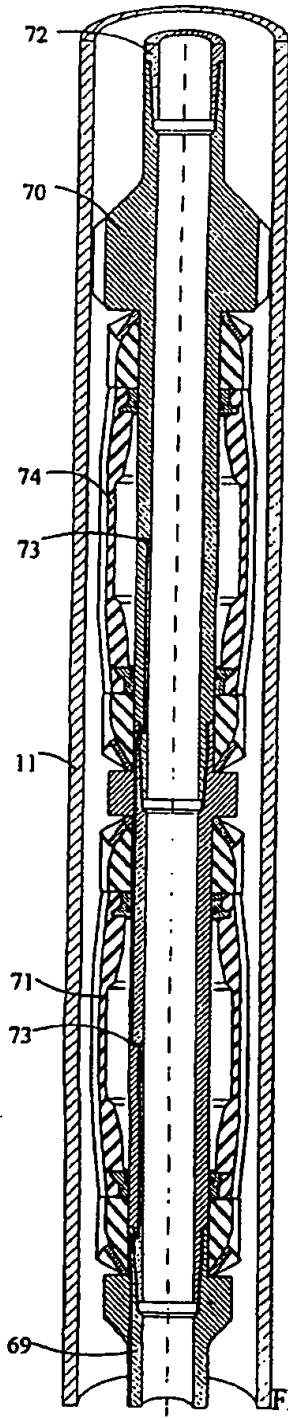

FIG. 1A

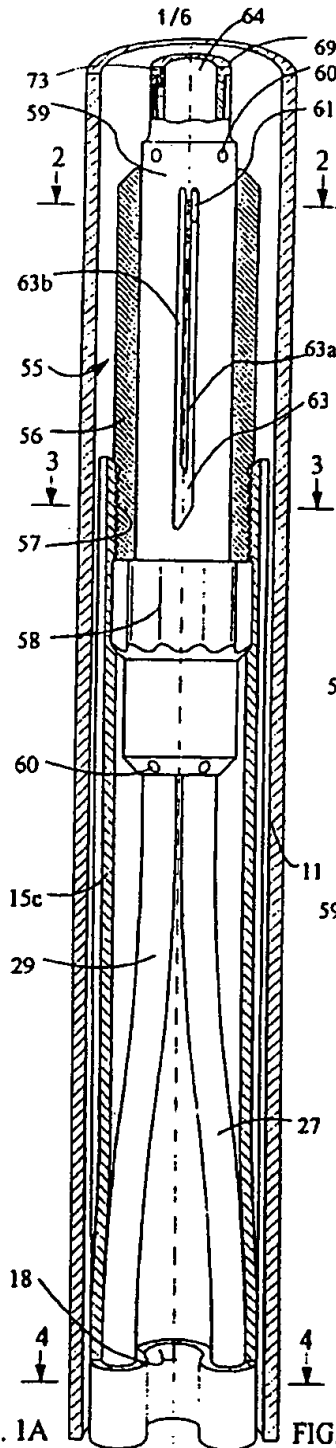

FIG. 1B

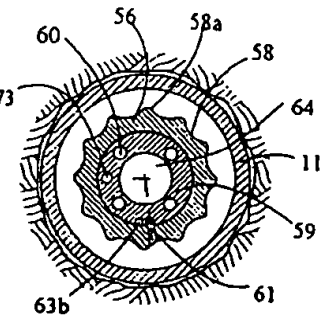

FIG. 2

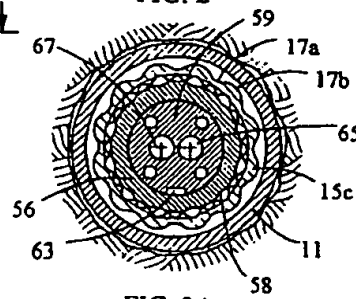

FIG. 3A

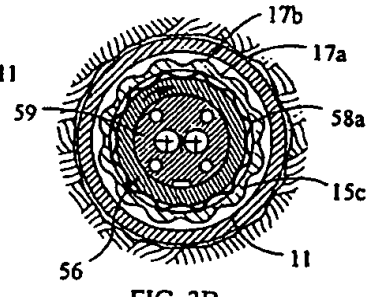

FIG. 3B

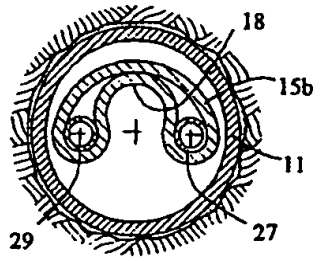
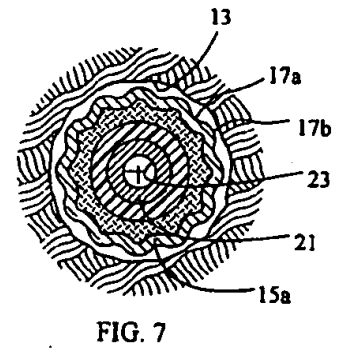
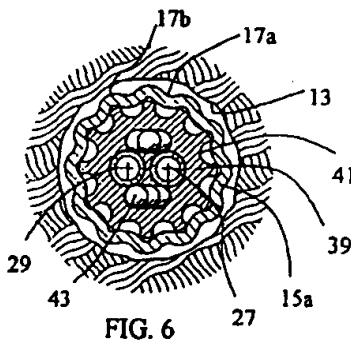
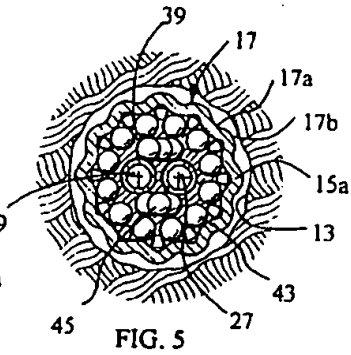
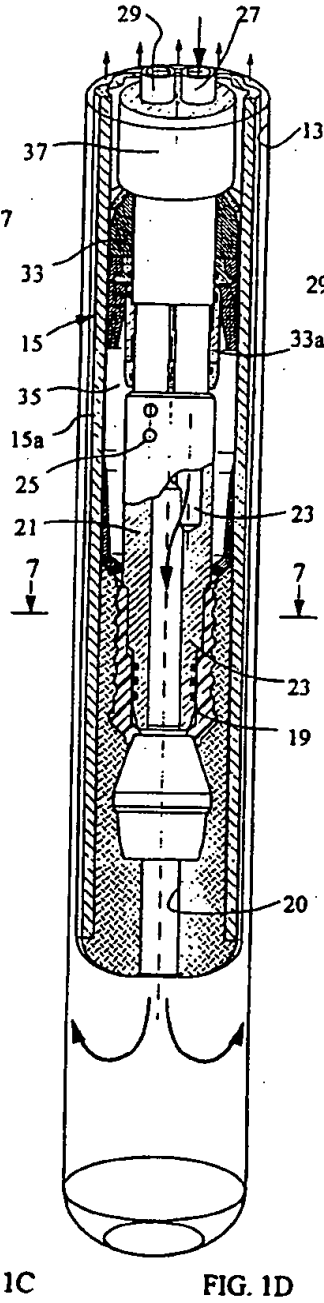
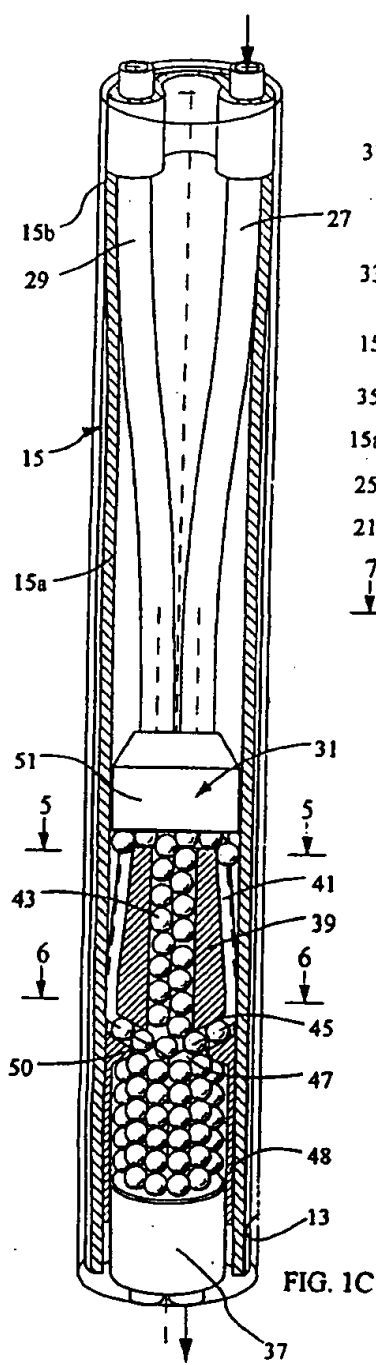
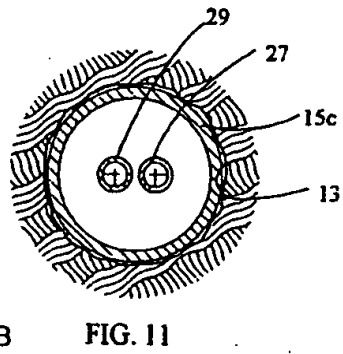
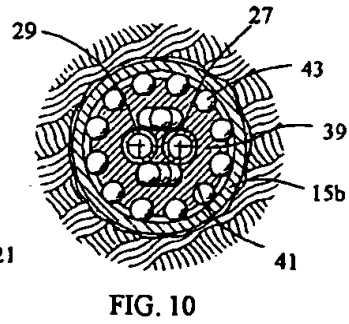
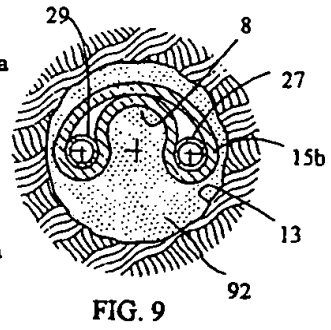
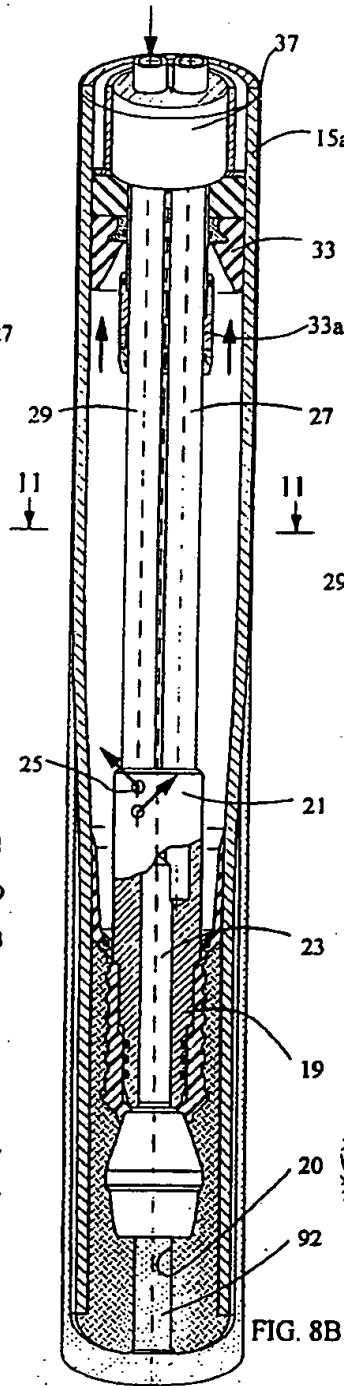
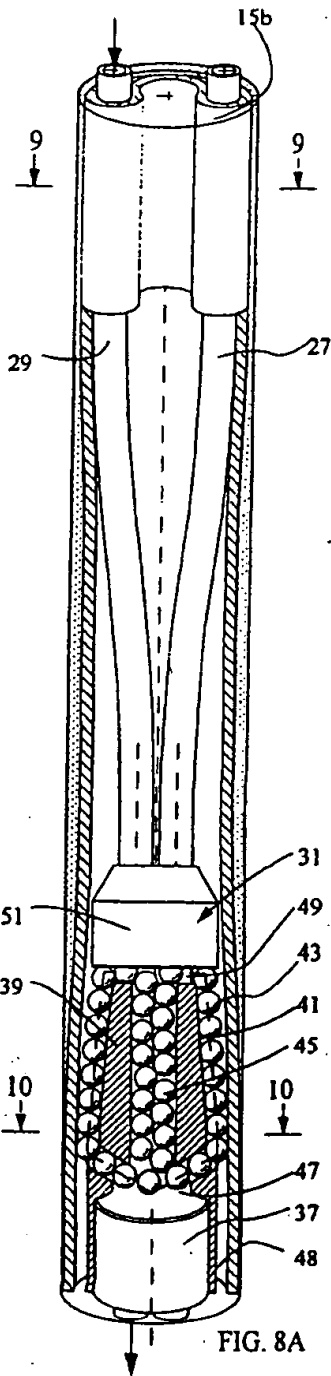
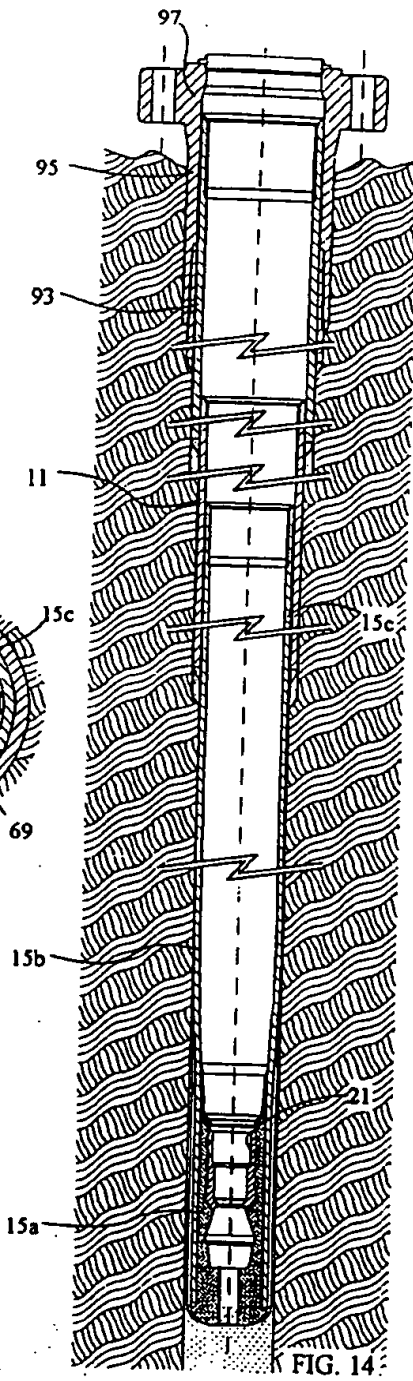
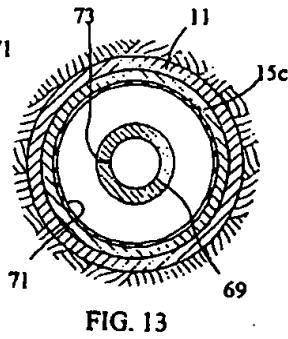
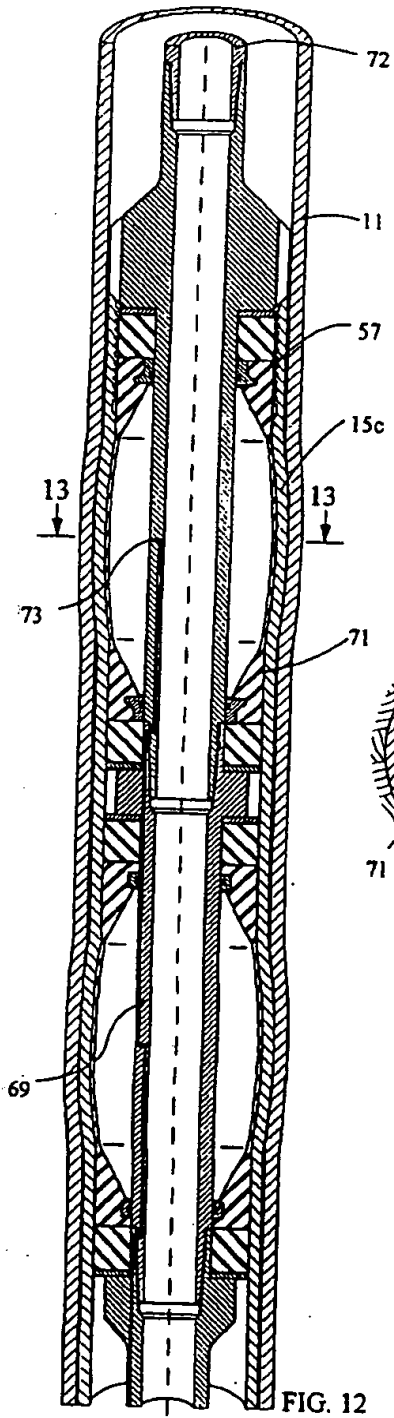
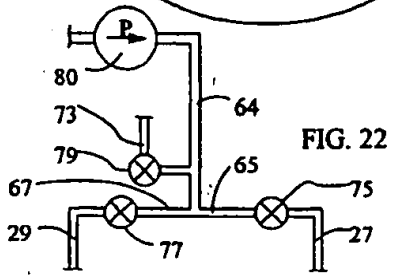
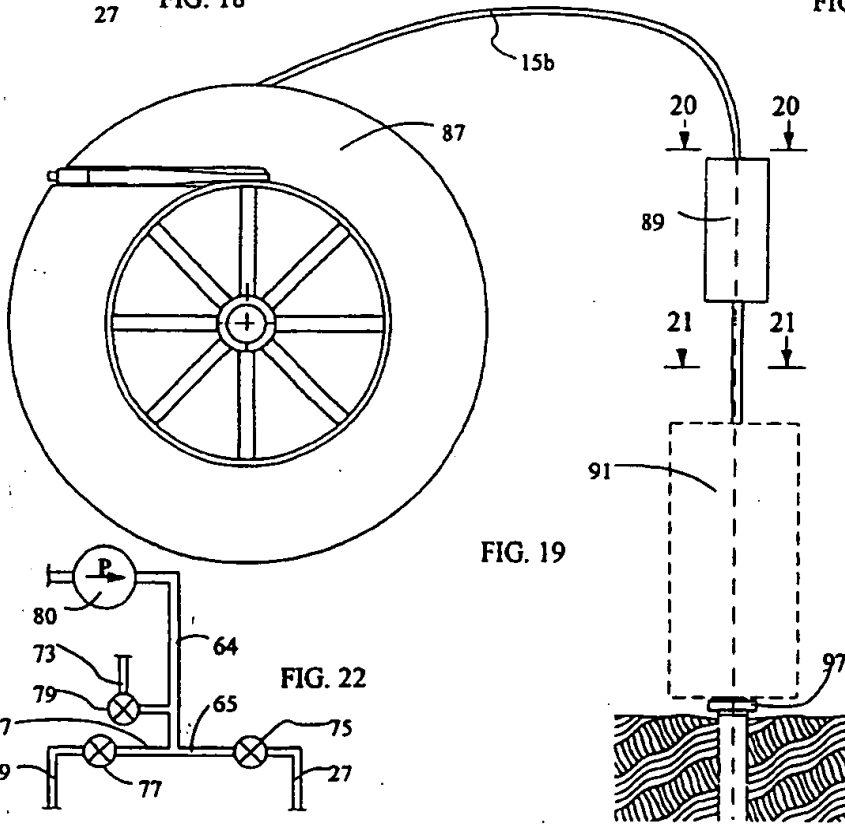
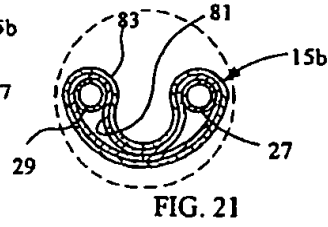
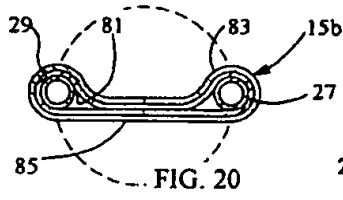
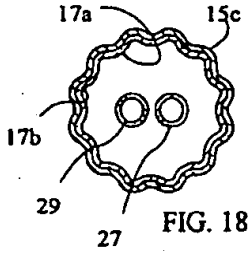
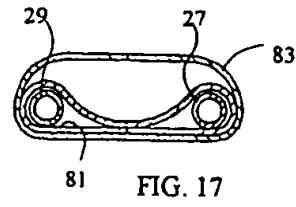
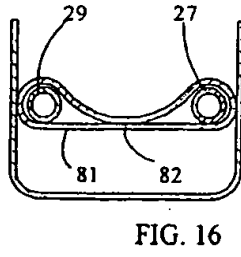
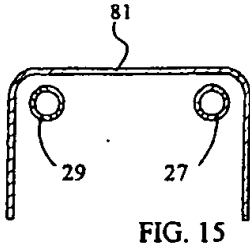

FIG. 4









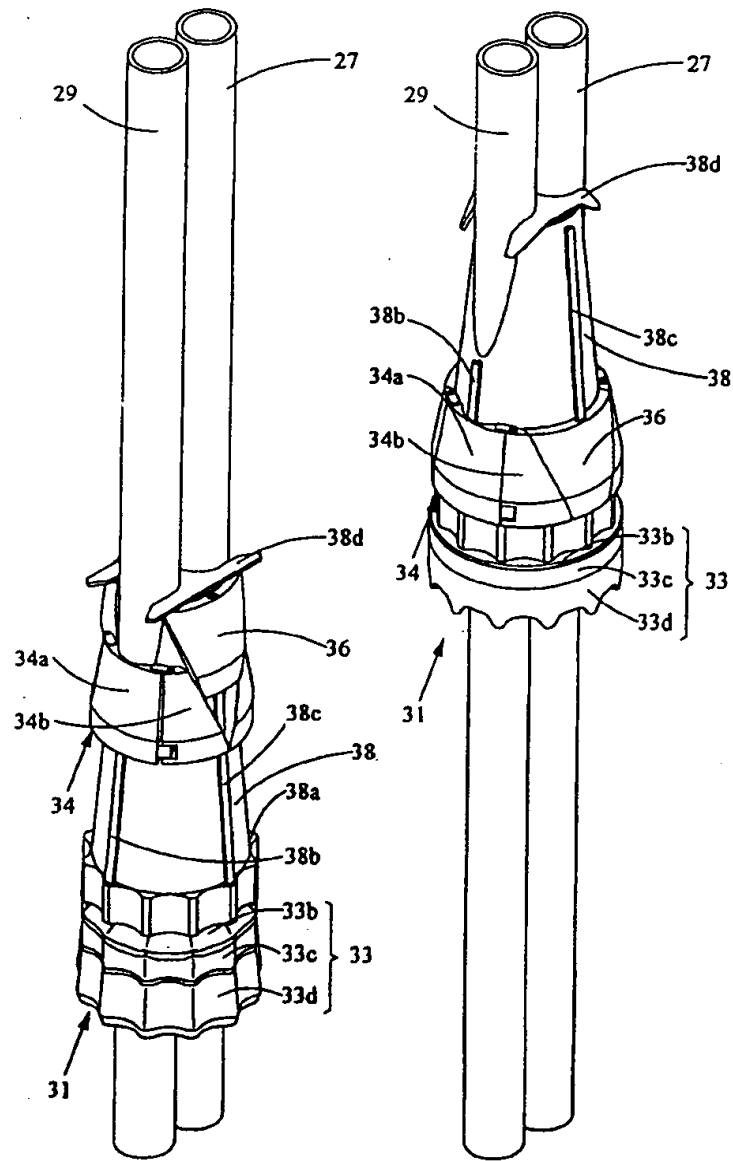

FIG. 23

FIG. 24

INTERNATIONAL SEARCH REPORT

International Application No

PCT/IB 97/00994

<p>A. CLASSIFICATION OF SUBJECT MATTER IPC 6 E21B43/10 E21B19/22</p> <p>According to International Patent Classification (IPC) or to both national classification and IPC</p>														
<p>B. FIELDS SEARCHED</p> <p>Minimum documentation searched (classification system followed by classification symbols) IPC 6 E21B</p> <p>Documentation searched other than minimum documentation to the extent that such documents are included in the fields searched</p> <p>Electronic data base consulted during the international search (name of data base and, where practical, search terms used)</p>														
<p>C. DOCUMENTS CONSIDERED TO BE RELEVANT</p> <table border="1"> <thead> <tr> <th>Category</th> <th>Citation of document, with indication, where appropriate, of the relevant passages</th> <th>Relevant to claim No.</th> </tr> </thead> <tbody> <tr> <td>Y</td> <td> US 5 337 823 A (NOBILEAU PHILIPPE C) 16 August 1994 see column 7, line 32 - column 9, line 10 see column 3, line 32-37 see column 11, line 54 - column 13, line 6 see column 14, line 18-21 see figures 1A, 1B, 6-10 --- </td> <td>1, 13, 19</td> </tr> <tr> <td>Y</td> <td> US 5 291 956 A (MUELLER MARK D ET AL) 8 March 1994 see column 7, line 55-58 see column 9, line 4-5 --- </td> <td>1, 13, 19</td> </tr> <tr> <td>A</td> <td> US 5 425 559 A (NOBILEAU PHILIPPE) 20 June 1995 see column 1, line 35-42 --- -/-- </td> <td>1, 19</td> </tr> </tbody> </table>			Category	Citation of document, with indication, where appropriate, of the relevant passages	Relevant to claim No.	Y	US 5 337 823 A (NOBILEAU PHILIPPE C) 16 August 1994 see column 7, line 32 - column 9, line 10 see column 3, line 32-37 see column 11, line 54 - column 13, line 6 see column 14, line 18-21 see figures 1A, 1B, 6-10 ---	1, 13, 19	Y	US 5 291 956 A (MUELLER MARK D ET AL) 8 March 1994 see column 7, line 55-58 see column 9, line 4-5 ---	1, 13, 19	A	US 5 425 559 A (NOBILEAU PHILIPPE) 20 June 1995 see column 1, line 35-42 --- -/--	1, 19
Category	Citation of document, with indication, where appropriate, of the relevant passages	Relevant to claim No.												
Y	US 5 337 823 A (NOBILEAU PHILIPPE C) 16 August 1994 see column 7, line 32 - column 9, line 10 see column 3, line 32-37 see column 11, line 54 - column 13, line 6 see column 14, line 18-21 see figures 1A, 1B, 6-10 ---	1, 13, 19												
Y	US 5 291 956 A (MUELLER MARK D ET AL) 8 March 1994 see column 7, line 55-58 see column 9, line 4-5 ---	1, 13, 19												
A	US 5 425 559 A (NOBILEAU PHILIPPE) 20 June 1995 see column 1, line 35-42 --- -/--	1, 19												
<p><input checked="" type="checkbox"/> Further documents are listed in the continuation of box C. <input checked="" type="checkbox"/> Patent family members are listed in annex.</p>														
<p>Special categories of cited documents</p> <p>"A" document defining the general state of the art which is not considered to be of particular relevance</p> <p>"E" earlier document but published on or after the international filing date</p> <p>"L" document which may throw doubts on priority claim(s) or which is cited to establish the publication date of another claim or other special reason (as specified)</p> <p>"O" document referring to an oral disclosure, use, exhibition or other means</p> <p>"P" document published prior to the international filing date but later than the priority date claimed</p> <p>"T" later document published after the international filing date or priority date and not in conflict with the application but cited to understand the principle or theory underlying the invention</p> <p>"X" document of particular relevance; the claimed invention cannot be considered novel or cannot be considered to involve an inventive step when the document is taken alone</p> <p>"Y" document of particular relevance; the claimed invention cannot be considered to involve an inventive step when the document is combined with one or more other such documents, such combination being obvious to a person skilled in the art</p> <p>"Z" document member of the same patent family</p>														
<p>Date of the actual completion of the international search</p> <p>1 December 1997</p>		<p>Date of mailing of the international search report</p> <p>08/12/1997</p>												
<p>Name and mailing address of the ISA</p> <p>European Patent Office, P. B. 5818 Patentstr. 2 NL - 2280 HV Rijswijk Tel. (+31-70) 340-2040, Tx. 31 651 epo nl Fax (+31-70) 340-3016</p>		<p>Authorized officer</p> <p>Schouten, A</p>												

Form PCT/ISA/210 (second sheet) (July 1992)

INTERNATIONAL SEARCH REPORT

International Application No
PCT/IB 97/00994

C. (Continuation) DOCUMENTS CONSIDERED TO BE RELEVANT		
Category	Citation of document, with indication, where appropriate, of the relevant passages	Relevant to claim No.
A	WO 96 22452 A (SHELL INT RESEARCH ;SHELL CANADA LTD (CA)) 25 July 1996 see column 4, line 31 - column 8, line 18 see figures 1,2 ---	1,19
A	US 3 489 220 A (KINLEY MYRON M) 13 January 1970 see column 2, line 37-50 see figure 1 ---	1,19
A	US 5 411 085 A (MOORE BRIAN K ET AL) 2 May 1995 see the whole document -----	1,19

2

INTERNATIONAL SEARCH REPORT

Information on patent family members

International Application No.

PCT/IB 97/00994

Patent document cited in search report	Publication date	Patent family member(s)	Publication date
US 5337823 A	16-08-94	FR 2662207 A	22-11-91
		FR 2668241 A	24-04-92
		FR 2671787 A	24-07-92
		AU 667661 B	04-04-96
		AU 7962691 A	10-12-91
		CA 2083156 C	19-03-96
		EP 0527932 A	24-02-93
		WO 9118180 A	28-11-91
US 5291956 A	08-03-94	NONE	
US 5425559 A	20-06-95	FR 2664355 A	10-01-92
		AU 8104091 A	04-02-92
		EP 0536256 A	14-04-93
		WO 9201139 A	23-01-92
WO 9622452 A	25-07-96	AU 4487196 A	07-08-96
		EP 0804678 A	05-11-97
		NO 973280 A	15-07-97
		US 5667011 A	16-09-97
		ZA 9600241 A	14-08-96
US 3489220 A	13-01-70	NONE	
US 5411085 A	02-05-95	CA 2134273 A	02-05-95
		FR 2712024 A	12-05-95
		FR 2716929 A	08-09-95
		FR 2716930 A	08-09-95
		FR 2716927 A	08-09-95
		FR 2716925 A	08-09-95
		FR 2716924 A	08-09-95
		FR 2716926 A	08-09-95
		GB 2283517 A,B	10-05-95
		GB 2287270 A,B	13-09-95
		NO 943824 A	02-05-95
		US 5425420 A	20-06-95
		US 5411081 A	02-05-95
		US 5423383 A	13-06-95
		US 5413170 A	09-05-95
US 5465793 A	14-11-95		